

Blue LED Chip

SL-MBIT0280-[V#W#L#]

- MOVPE epi-wafer of InGaN alloy films
- Normal type chip (**with Backside Aluminum Reflector**)
- ※ All samples are 100% tested and sorted, and user can consult about special specifications.

■ ABSOLUTE MAXIMUM RATINGS (Ta = 25 °C)

Item	Symbol	Maximum Rating	Unit
DC Forward Current	I_F	30	mA
Pulse Forward Current	I_{FP}	100	mA
Reverse Voltage	V_R	5	V
Operating Temperature	T_{opr}	-30 to +85	°C
Storage Temperature	T_{stg}	-40 to +100	°C
ESD sensitivity (HBM) *	V_{ESDS}	2000	V

*ESD testing result is based on statistic measurements. Seller does not give assurance for every chip.

■ OPTICAL AND ELECTRICAL CHARACTERISTICS (Ta = 25 °C)

Item	Symbol	Condition		Min	Typ	Max	Unit
Forward Voltage	V_F	$I_F=20mA$	V_1	2.8	2.9	3.0	V
			V_2	3.0	3.1	3.2	
			V_3	3.2	3.3	3.4	
Reverse Current	I_R	$V_R=5V$		-	-	1	μA
Wavelength	λ_D	$I_F=20mA$	W_1	465	-	467.5	nm
			W_2	467.5	-	470	
			W_3	470	-	472.5	
			W_4	472.5	-	475	
Luminous Intensity	I_v	$I_F=20mA$	I_1	80	-	90	mcd
			I_2	90	-	100	
			I_3	100	-	110	
			I_4	110	-	120	
			I_5	120	-	130	
			I_6	130	-	140	
			-	...	
			I_{14}	210	-	220	

■ CHIP DESCRIPTION

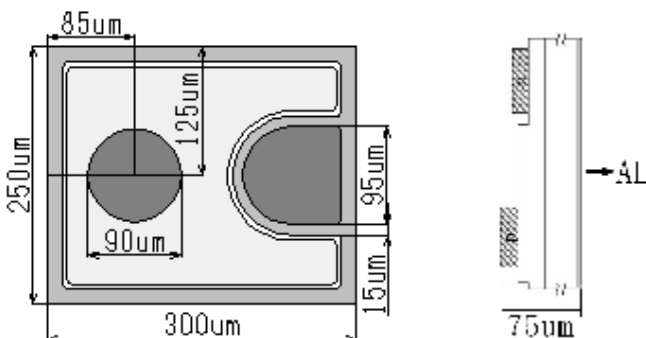

■ MECHANICAL SPECIFICATION

Description	Dimension
Emission Area	200μm x 250μm
Bottom Area	250μm x 300μm (±10μm)
Chip Thickness	75μm (±5μm)
N-pad	Φ=95μm
P-pad	Φ=90μm
Electrodes Spacing	15μm
Electrode material	AL